

Copyright © 2006 av RG Mekaniska AB. All information på ritningen är RG Mekaniska AB:s egendom. Vid kopiering av detalj eller hel sammanställning utan skriftligt godkännande av RG Mekaniska AB begås lagbrott.

Nr	Ändring	Datum	Godk av
----	---------	-------	---------

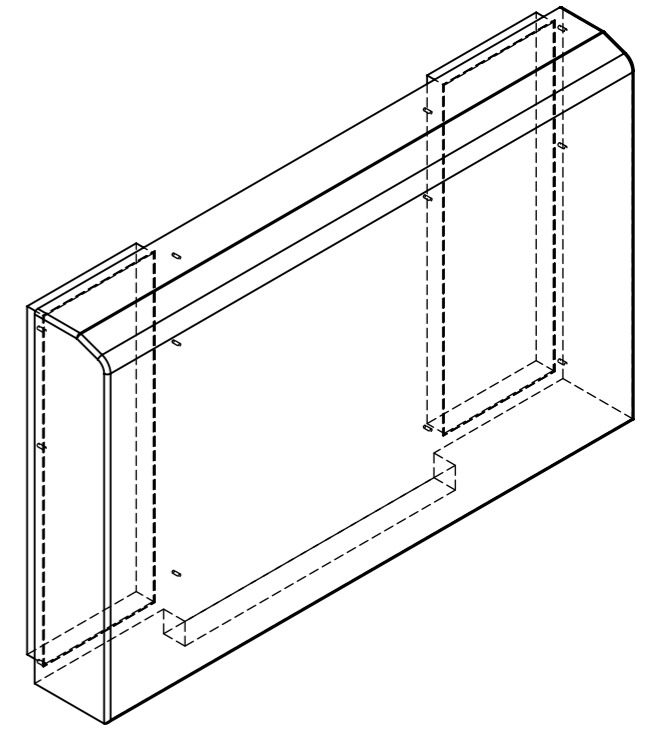
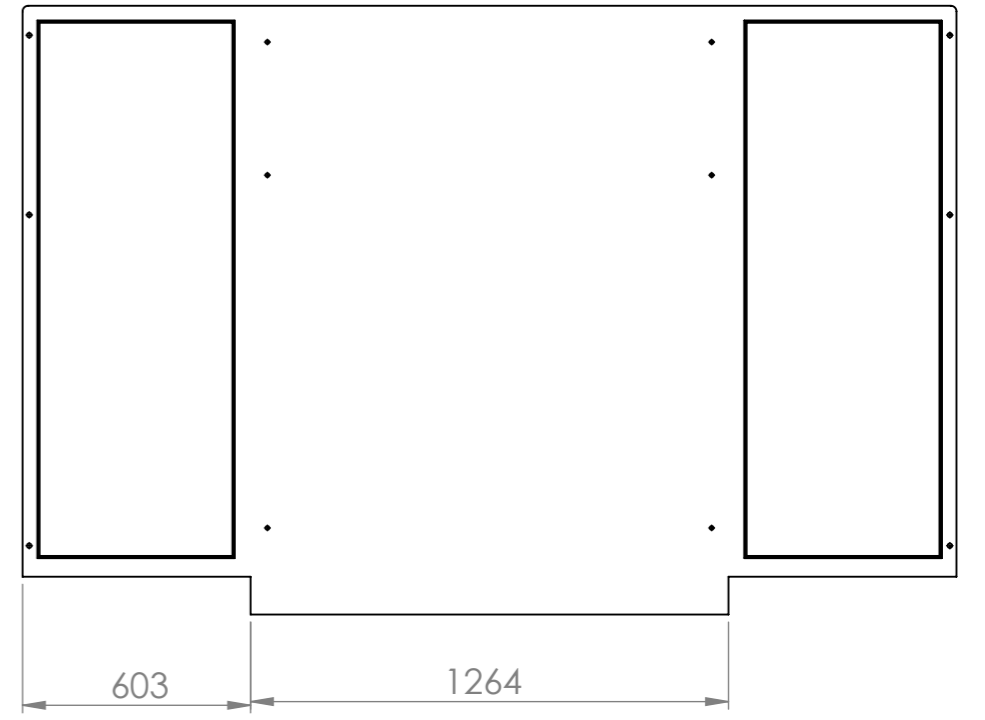
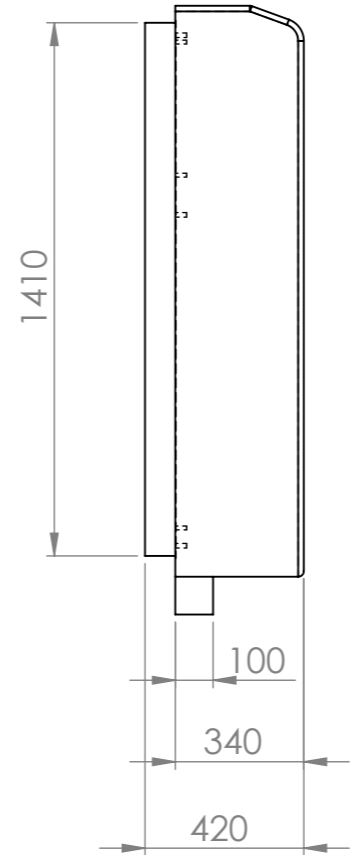
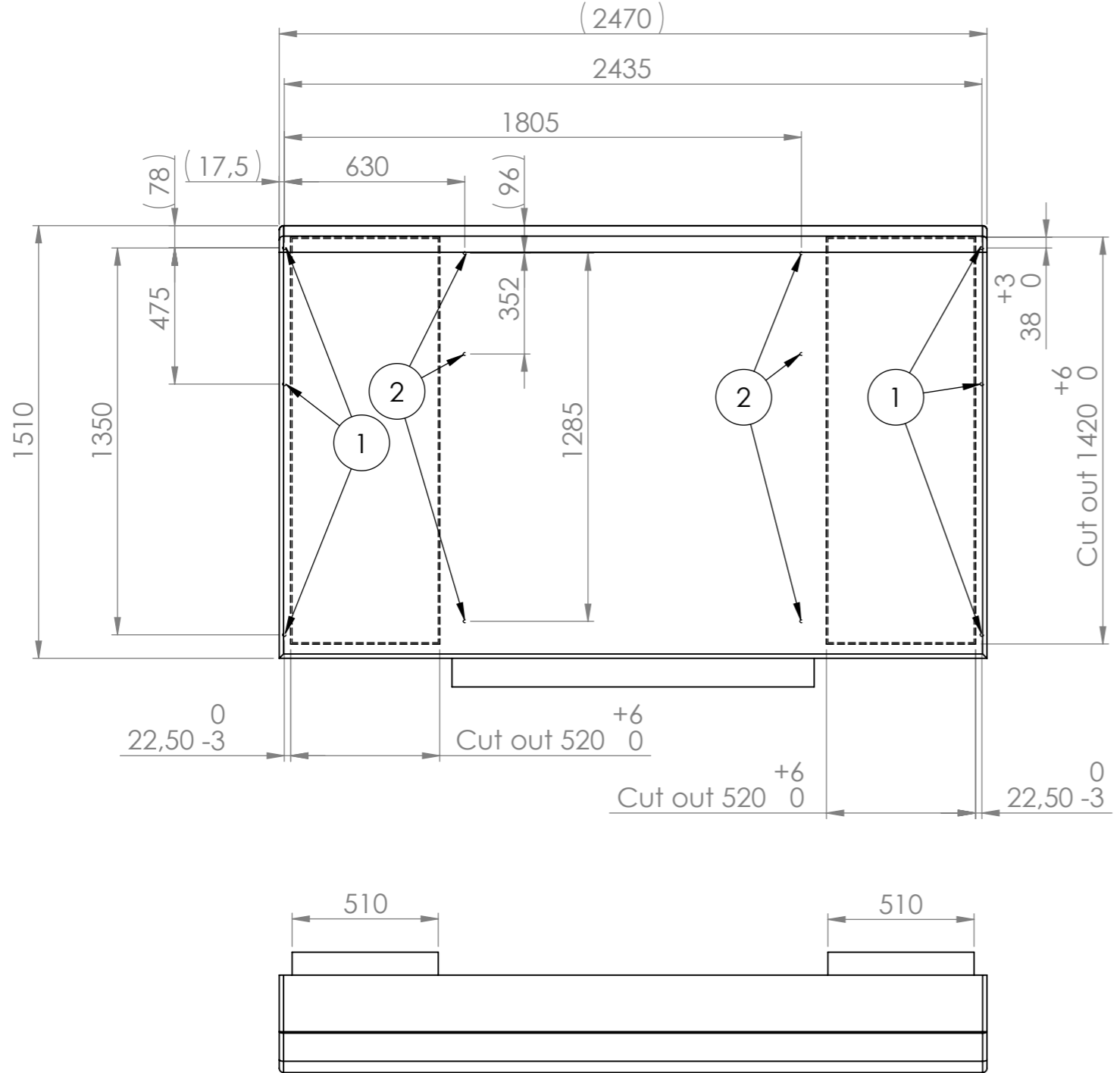

- Mounting holes are shown with measurement from upper left hole
- Outer mounting holes in box 6 no marked with "1" should be clearance holes for M10 appr Ø12
- Inner mounting holes in box 6 no marked with "2" could be either threaded M12 or clearance holes Ø14

Ritad av	Godk.	Ritningsnummer	Kund	Generella toleranser	Vikt (kg)		A3	Skala	Sida
Hultsteins AB		Slimline 215 Installation dimensions			Revision	Datum		1:50	1/1
						Ritningsnummer		1392-98-00-04	
								2022-08-24	